



HAL
open science

Presence of larvae of lampreys, *Lampetra* sp. (Cephalaspidomorphi, Petromyzontiformes), in a French Catalan basin

Rémy Arseno, Kevin Richarte, André Fonteneau, Gaël P.J. Denys

► To cite this version:

Rémy Arseno, Kevin Richarte, André Fonteneau, Gaël P.J. Denys. Presence of larvae of lampreys, *Lampetra* sp. (Cephalaspidomorphi, Petromyzontiformes), in a French Catalan basin. *Cybium: Revue Internationale d'Ichtyologie*, 2018, 42 (2), pp.216 - 218. 10.26028/cybium/2018-422-012 . mnhn-02310570

HAL Id: mnhn-02310570

<https://mnhn.hal.science/mnhn-02310570v1>

Submitted on 10 Oct 2019

HAL is a multi-disciplinary open access archive for the deposit and dissemination of scientific research documents, whether they are published or not. The documents may come from teaching and research institutions in France or abroad, or from public or private research centers.

L'archive ouverte pluridisciplinaire **HAL**, est destinée au dépôt et à la diffusion de documents scientifiques de niveau recherche, publiés ou non, émanant des établissements d'enseignement et de recherche français ou étrangers, des laboratoires publics ou privés.



Received: 11 Jul. 2017
 Accepted: 17 Oct. 2017
 Editor: R. Causse

Presence of larvae of lampreys, *Lampetra* sp. (Cephalaspidomorphi, Petromyzontiformes), in a French Catalan basin

by

Rémy ARSENTO* (1), Kevin RICHARTE (1), André FONTENEAU (1) & Gaël P.J. DENYS (2, 3)

Résumé. – Présence d’ammocètes de lamproies *Lampetra* sp. (Cephalaspidomorphi, Petromyzontiformes) dans un bassin catalan français.

Des ammocètes de lamproies ont été récemment capturées pour la première fois dans un cours d’eau de Catalogne française, la Têt. Les identifications morphologique et moléculaire ont démontré que ces ammocètes appartiennent au complexe [*Lampetra fluviatilis* / *Lampetra planeri*]. Les lamproies et leurs frayères étant protégées en France, cette étude aura une incidence sur la gestion du cours d’eau de la Têt.

Key words. – Petromyzontidae – *Lampetra fluviatilis* / *Lampetra planeri* – France – Têt River – Ammocoele.

The Têt is a French Catalan coastal river starting at the foot of the Pic Carlit (altitude 2405 m) in the Pyrenees. It crosses the Pyrénées-Orientales department from West to East along 115 km, through Perpignan, and ends in the Mediterranean Sea at Canet-en-Roussillon (Fig. 1). It is characterized by a predominantly Mediterranean rainfall regime with two noticeable low periods in summer and in the middle of winter, and periods of high water during snowmelt as well as in autumn with possibilities of “Cévenol”-type violent floods (Curt and Davy, 1990). Two large dams structure its course and its hydrology, the Bouillouses Dam, a few kilometres from the source (hydroelectricity) and the Vinça Dam at mid-course (flood crash and low water support).

During an ichthyological inventory by the French national agency for water and aquatic environments (Office National de l’Eau et des Milieux Aquatiques, ONEMA) in the Têt River at Nefiach in 2012, a lamprey larva (or ammocoete) was caught. According to the ONEMA inventory networks, this catch was the first record in the Pyrénées-Orientales department since 1990, and the second one in a French Mediterranean basin with the specimen fished in the Fresquel stream (Aude basin) in 2003. No lamprey was recorded in the area in the last edition of *Les Poissons d’eau douce de France* (Keith *et al.*, 2011). Eight other specimens were caught in 2015 and 2016 at Millas (1.6 km downstream from Nefiach), and six at Ille-sur-Têt (1.4 km upstream) (Arsento and Fonteneau, pers. com.; Richarte, unpubl. data).

The 7th September 2016, the ONEMA did an inventory at Nefiach, using electrofishing. The aim of this study was to confirm the

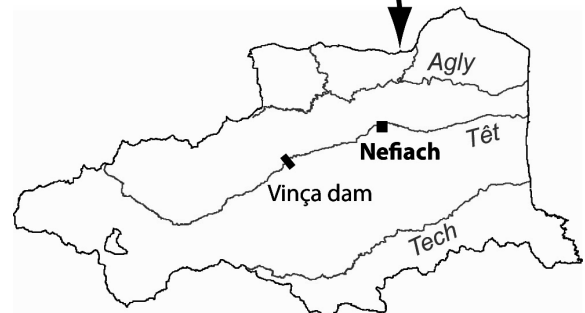

Figure 1. – The Têt River in the Pyrénées-Orientales department and the lamprey location at Nefiach (square).

presence of lampreys at this location, and to allow to identify which lamprey species is present.

MATERIAL AND METHODS

The fish inventory “Têt River at Nefiach” location is situated 30 km from the mouth, downstream of the two large dams. It is characterized by a succession of flat surfaces and currents on coarse substrates along 403 m, as well as a large deep hydraulic annex with a silt-silty substrate loaded with organic matter. Apart from the

- (1) Agence Française pour la Biodiversité, Service départemental des Pyrénées-Orientales, 2, boulevard du Docteur Ecoffier, 66300 Thuir, France. [kevin.richarte@gmail.com] [andre.fonteneau@afbiodiversite.fr]
- (2) Unité Mixte de Service Patrimoine Naturel – Centre d’expertise et de données (UMS 2006 AFB – CNRS – MNHN), Muséum national d’Histoire naturelle, 36 rue Geoffroy Saint-Hilaire CP 41, 75005 Paris, France.
- (3) Muséum national d’Histoire naturelle, UMR 7208 (CNRS – IRD – UPMC – MNHN) BOREA, CP26, 43 rue Cuvier, 75005 Paris, France. [gael.denys@mnhn.fr]

* Corresponding author [remy.arsento@afbiodiversite.fr]

stable hydraulic annex and wooded banks, the course of this river is dynamic and its bed is changing.

Fish were caught by electrofishing with the punctual abundance sampling method (Nelva *et al.*, 1979) and a particular effort for the prospection of the hydraulic annex according to the protocol of Harvey and Cowx (2003), more adapted for lamprey sampling.

Specimens were fixed and preserved in 95% EtOH for DNA identification using progressive concentration of EtOH in the span of a few hours. They were morphologically identified following the characters in Taverny and Elie (2010). Muscle samples were taken on each specimen for molecular identification [or DNA Barcoding *sensu* Hebert *et al.* (2003)] with the cytochrome oxidase subunit 1 marker (COI, 652 bp). DNA extraction, PCR products and sequencing were performed according to Dettai *et al.* (2011). COI sequences were deposited in the LPPPO (*Lampetra planeri* of the Pyrénées-Orientales) project folder in the Barcode of Life database (BOLD, www.boldsystems.org; Ratnasingham and Hebert, 2007) and GenBank (accession numbers MG574309 to MG574311).

COI sequences were integrated with 91 sequences of *Lampetra* spp. and *Petromyzon marinus* Linnaeus, 1758 (Appendix 1). Aligning and NJ barcoding tree were performed under MEGA 7 (Kumar *et al.*, 2016) with the Kimura 2 parameter model (K2P; Kimura, 1980) and bootstrap values (1000 replicates; Felsenstein, 1985).

RESULTS

Six ammocoetes were caught among other species: *Gobio occitaniae* Kottelat & Persat, 2005, *Phoxinus septimaniae* Kottelat, 2007, *Barbus meridionalis* Risso, 1827, *Barbatula barbatula* (Linnaeus, 1758), *Squalius laietanus* Doadrio *et al.*, 2007, *Salmo trutta* Linnaeus, 1758, *Leuciscus burdigalensis* Valenciennes, 1844, *Anguilla anguilla* Linnaeus, 1758, *Gasterosteus aculeatus* Linnaeus, 1758 and *Rutilus rutilus* (Linnaeus, 1758). Three ammocoetes (catalog number MNHN 2016-0363; Fig. 2A) were fixed and preserved for morphological and molecular identification.

According to the diagnostic criterions for ammocoetes given by Taverny and Elie (2010), we identified morphologically these lampreys. Each specimen has a depigmented zone on both side of the

snout (Fig. 2B), and their caudal fins do not present any pigmentation (Fig. 2C). Thus, these larvae belong to the genus *Lampetra*. Ammocoetes do not yet display characters allowing the distinction between *L. fluviatilis* Linnaeus, 1758 and *L. planeri* Bloch, 1784.

The barcoding analysis tree confirms this identification as the complex [*Lampetra fluviatilis* + *Lampetra planeri*] without precis-ing to which species they belong (Fig. 3).

DISCUSSION

The presence of lampreys *Lampetra* sp. is attested on the Têt River, downstream of the Vinça Dam. Morphological and molecular determinations are in agreement to identify them as belonging to the complex [*Lampetra fluviatilis* + *Lampetra planeri*]. However, there are twelve transverse structures that are impassable for most of the year and only two others are equipped with fish passes between the sea and the location at Nefiach. *L. fluviatilis*, a supposed amphihaline species, is not able to cross these kinds of barriers without a fish pass (Taverny and Elie, 2010). Without adult specimens, we could assume these larvae are *L. planeri* (a freshwater species) ammocoetes. Nevertheless, some authors are doubtful about the distinction between these two species, with *L. planeri* as a neither non-parasitic nor amphihaline form of *L. fluviatilis* (*e.g.* Taverny and Elie, 2010; Knebelberger *et al.*, 2015; Tutman *et al.*, 2017). A taxonomic revision of this complex will be necessary in the future.

The Têt River is in a severe deficit of solid transport due to the presence of the Vinça Dam, blocking all inputs from the upstream and the intensive exploitation of gravel pits in the minor river until the 1980s. So, the favourable habitats for the ammocoetes growth are largely disrupted. About ten kilometres downstream of Millas, the Têt flows directly on the bedrock, offering no habitat for this taxon.

Lampreys *Lampetra* spp. belong to the list of species protected by the annex III of the Bern Convention (19th Sep. 1979) as well as in France since the 8th of December 1988, thus protecting their biotope. The spawning beds and their granulometry are also protected since the 27th of July 1990 and the 23rd of April 2008, respectively (Taverny and Elie, 2010). Prospection efforts on all the Têt basin



Figure 2. – A: Three of the six lamprey larvae, or ammocoetes, belonging to the genus *Lampetra* caught in the Têt River at Nefiach (MNHN 2016-0363). B, C: Enlargement of the head and tail showing the absence of pigmentation respectively on the snout and on the extremity of the caudal fin (arrows). Scale bars = 1 cm.

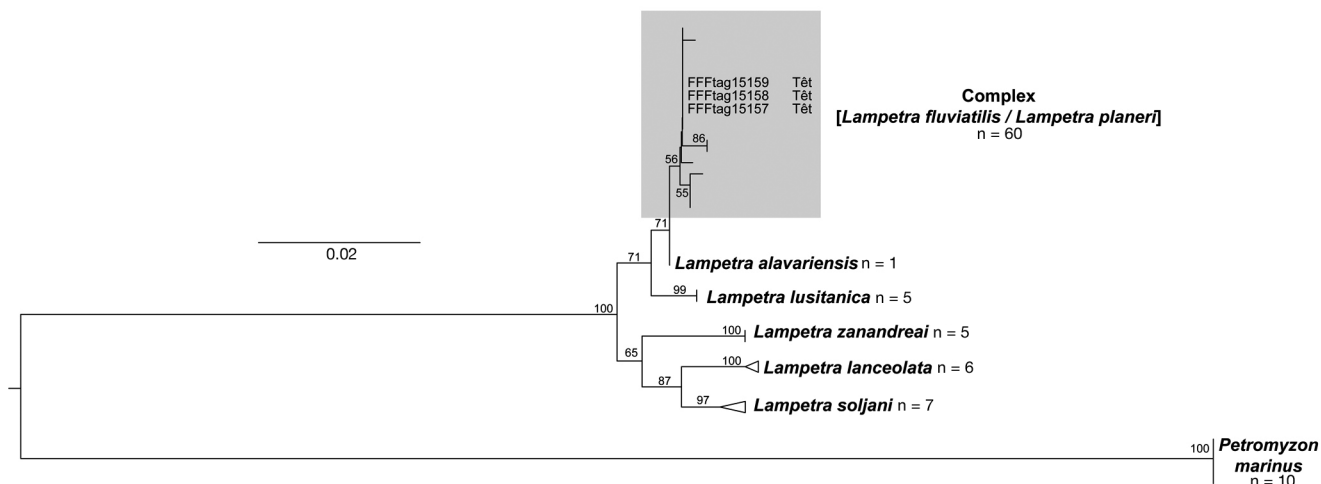

Figure 3. – Neighbour-Joining barcoding tree with the COI marker (642 bp) of European *Lampetra* spp. and *Petromyzon marinus* (94 specimens) identifying the three ammocoetes caught at Nefiach. Numbers at nodes correspond to bootstrap values. Grey box refers to the complex [*Lampetra fluviatilis* + *Lampetra planeri*].

and adjacent catchments must be done in order to map lamprey occurrences, protect their habitats and manage their populations.

Acknowledgements. – This work was supported by the Muséum national d’Histoire naturelle (MNHN), the UMR BOREA 7208 and the Agence Française pour la Biodiversité (AFB) especially the departmental service of the Pyrénées-Orientales (SD66). We thank the “Service de Systématique Moléculaire” (UMS2700 MNHN/CNRS) for granting access to its technical platform. And finally, we are grateful to M. Hauteœur for checking the English.

REFERENCES

CURT T. & DAVY L., 1990. – Précipitations et écoulement dans le bassin de la Têt. *Espace rural*, 21: 89-176.

DETTAI A., LAUTREDOU A.C., BONILLO C. *et al.* [18 authors], 2011. – The actinopterygian diversity of the CEAMARC cruises: barcoding and molecular taxonomy as a multi-level tool for new findings. *Deep-Sea Res. Pt. II*, 58: 250-263.

HARVEY J.P. & COWX I.G., 2003. – Monitoring the River, Brook and Sea Lamprey, *Lampetra fluviatilis*, *L. planeri* and *Petromyzon marinus*. 32 p. Conserving Natura 2000 Rivers Monitoring S. 5, Peterborough: English Nature.

HEBERT P.D.N., RATNASINGHAM S. & DE WAARD J.R., 2003. – Barcoding animal life: cytochrome c oxidase subunit I divergences among closely related species. *Philos. Trans. R. Soc. Lond. B Biol. Sci.*, 270: 596-599.

FELSENSTEIN J., 1985. – Confidence limits on phylogenies: an approach using the bootstrap. *Evolution*, 39: 783-791.

KEITH P., PERSAT H., FEUNTEUN E. & ALLARDI J., 2011. – Les Poissons d’Eau douce de France. 552 p. Collection Inventaires et Biodiversités. Mèze: Biotope Éditions, Paris: Publications scientifiques du Muséum.

KIMURA M., 1980. – A simple method for estimating evolutionary rate of base substitutions through comparative studies of nucleotide sequences. *J. Mol. Evol.*, 16: 111-120.

KNEBELSBERGER T., DUNZ A.R., NEUMANN D. & GEIGER M.F., 2015. – Molecular diversity of Germany’s freshwater fishes and lampreys assessed by DNA barcoding. *Mol. Ecol. Res.*, 15: 562-572.

KUMAR S., STECHER G. & TAMURA K., 2016. – MEGA7: molecular evolutionary genetics analysis version 7.0 for bigger data sets. *Mol. Biol. Evol.*, 33: 1870-1874.

NELVA A., PERSAT H. & CHESSEL D., 1979. – Une nouvelle méthode d’étude des peuplements ichthyologiques dans les grands cours d’eau par échantillonnage ponctuel d’abondance. *C. R. Acad. Sci. Paris, Sér. D*, 289: 679-791.

RATNASINGHAM S. & HEBERT P.D.N., 2007. – BOLD: The Barcode of Life Data System (www.barcodinglife.org). *Mol. Ecol. Notes*, 7: 355-364.

TAVERNY C. & ELIE P., 2010. – Les lamproies en Europe de l’Ouest : Écophases, Espèces et Habitats. 111 p. Versailles: Quae Édition.

TUTMAN P., FREYHOF J., DULČIĆ J., GLAMUZINA B. & GEIGER M., 2017. – *Lampetra soljani*, a new brook lamprey from the southern Adriatic Sea basin (Petromyzontiformes: Petromyzontidae). *Zootaxa*, 4273(4): 531-548.

Appendix 1. – GenBank accession numbers of COI sequences by lamprey species used for DNA Barcoding analysis.

Lampetra sp.: France (Têt River): MG574309 to MG574311.

Lampetra alavariensis Mateus *et al.*, 2013: Portugal KJ553926.

Lampetra fluviatilis (Linnaeus, 1758): Germany: KJ553672, KJ553858, KM286694, KM286696 to KM286709; Russia: HQ579125, JN026947 to JN026950; Sweden: KJ128518, KJ128519. *Lampetra lanceolata* Kux & Steiner, 1972: Turkey: HQ579127, JN026951 to JN026955. *Lampetra lusitanica* Mateus *et al.*, 2013: Portugal: KJ553702, KJ553927, KJ554026, KJ554050, KJ554076. *Lampetra planeri* (Bloch, 1784): Czech Republic: HQ960515 to HQ960710, HQ960601 to HQ960603, HQ960776 to HQ960780, HQ961029; Germany: KM286711, KM286717, KM373659, KM373674, KM373681; Italy: KJ553713, KJ553769, KJ553784, KJ553838, KJ553859, KJ553931, KJ554002, KJ554039; Portugal: KJ553735, KJ553760, KJ553779, KJ553946, KJ553967, KJ553986; Spain: KJ553766; Sweden: KJ128520, KJ128521. *Lampetra soljani* Tutman *et al.*, 2017: Bosnia and Herzegovina: KJ553665, KJ553778, KJ553990; Montenegro: KJ553756, KJ553819, KJ553874, KJ554074. *Lampetra zanandreae* Vladykox, 1955: Italy: KJ553679, KJ553721, KJ553744, KJ553930, KJ553977. *Petromyzon marinus* Linnaeus, 1758: Germany: KM286795, KM286797 to KM286802; Portugal: KJ554404; Sweden: KJ128572, KJ128573.